

**PREMIUM LIPLITE  
FIBERGLASS DOOR  
IN SWING / OUT SWING  
"NON-IMPACT"**

GENERAL NOTES

1. This product has been evaluated and is in compliance with the 2007 Florida Building Code (FBC) structural requirements including the "High Velocity Hurricane Zone" (HVHZ).
2. Product anchors shall be as listed and spaced as shown on details. Anchor embedment to base material shall be beyond wall dressing or stucco.
3. When used in the "HVHZ" this product is required to be protected with an impact resistant covering that complies with Section 1626 of the 2007 FBC.
4. When used in areas outside of the "HVHZ" requiring wind borne debris protection this product is required to be protected with an impact resistant covering that complies with Section 1609.1.2 of the FBC.
5. For 2x stud framing construction, anchoring of these units shall be the same as that shown for 2x buck masonry construction.
6. Site conditions that deviate from the details of this drawing require further engineering analysis by a licensed engineer or registered architect.
7. Outswing configuration using threshold item #25 meet water infiltration requirements for "HVHZ".
8. Inswing configurations and outswing configuration using threshold item #27 do not meet the water infiltration requirements for the "HVHZ" and shall be installed only in non-habitable areas or at habitable locations protected by an overhang or canopy such that the angle between the edge of canopy or overhang to sill is less than 45 degrees.

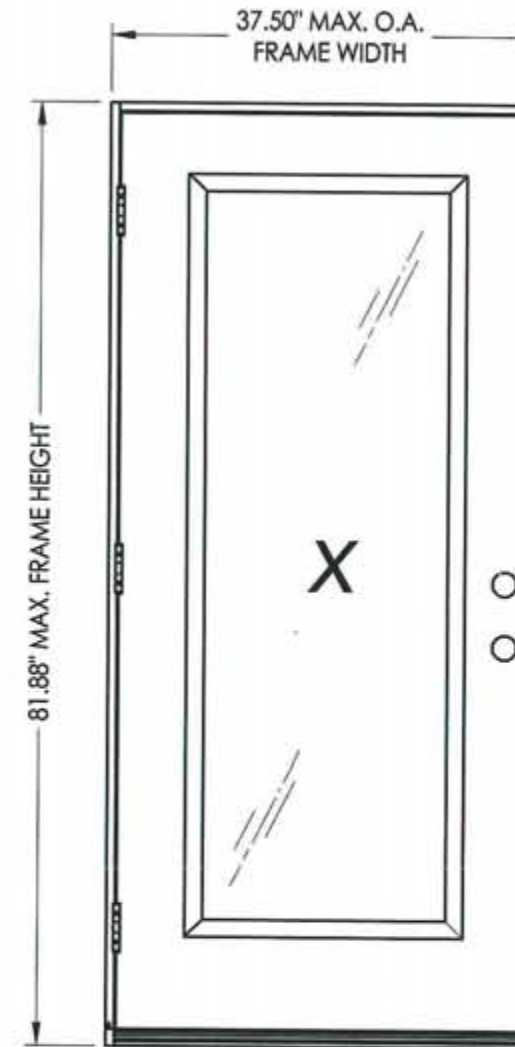

TABLE OF CONTENTS	
SHEET #	DESCRIPTION
1	Typical elevations, design pressures & general notes
2	Door panel construction details & glazing details
3	Horizontal cross sections
4	Vertical cross sections
5	Buck and frame anchoring - 2X buck masonry construction
6	Frame anchoring - 1X buck masonry construction
7	Components
8	Bill of materials

SWING	MAX. FRAME DIMENSION	GLASS TYPE	DESIGN PRESSURE (PSF)	
			POSITIVE	NEGATIVE
IN SWING	37.50" x 81.88"	G1	+47.0	-47.0
OUT SWING	37.50" x 80.75"		+47.0	-47.0

Documents Prepared By: **RW** BUILDING CONSULTANTS, INC.  
P.O. Box 230 Vairico FL 33595  
Phone No.: 813.659.9197  
Florida Board of Professional Engineers  
Certificate of Authorization No. 9813  
*Wendell W. Honey*  
Wendell W. Honey, P.E. No. 34158

PRODUCT: TRINITY GLASS INT'L  
PREMIUM LIPLITE FIBERGLASS  
PART OR ASSEMBLY: TYPICAL ELEVATION, DESIGN PRESSURES & GENERAL NOTES

NO.	DATE	BY	REVISIONS

DATE: 5/09/08  
SCALE: N.T.S.  
DWG. BY: YV  
CHK. BY: WWH  
DRAWING NO.: FL-11165.1  
SHEET 1 OF 8

© 2008 R.W. BUILDING CONSULTANTS INC.



R:\Projects\11165\11165.dwg, K:\DWG\Drawings\11165\11165.dwg, R:\Projects\11165\11165.dwg, Model

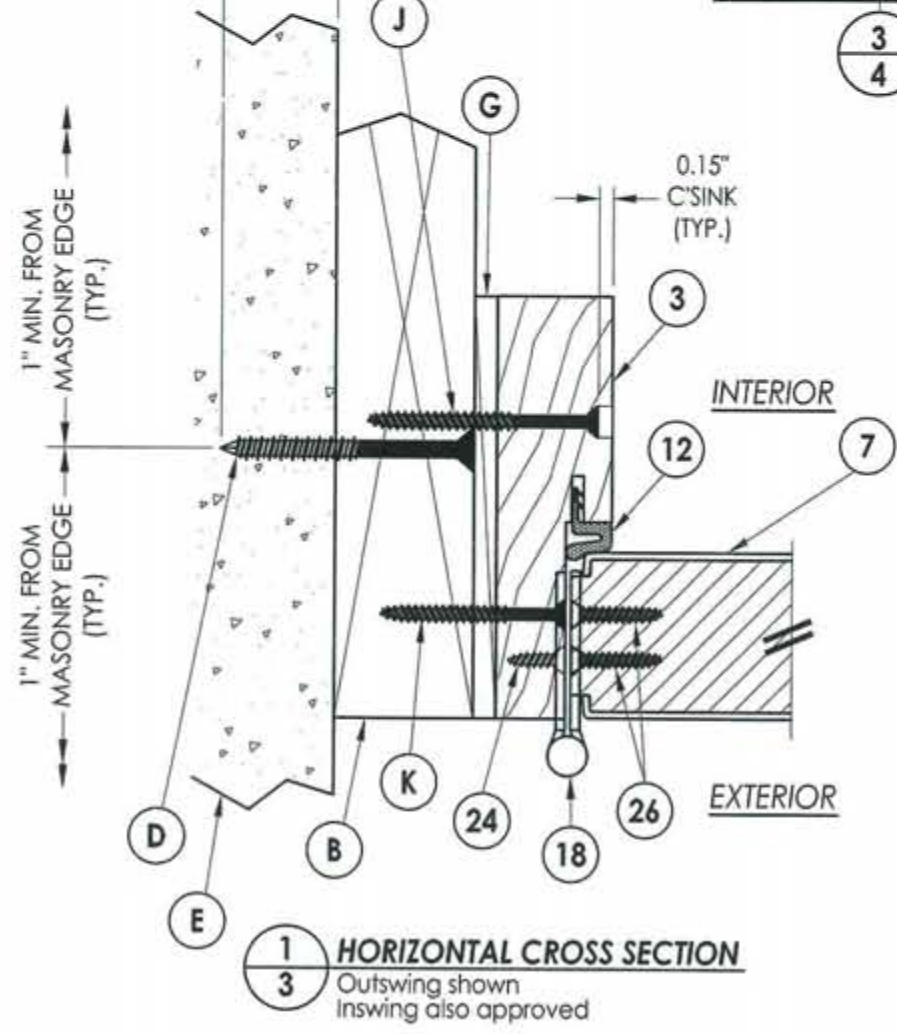
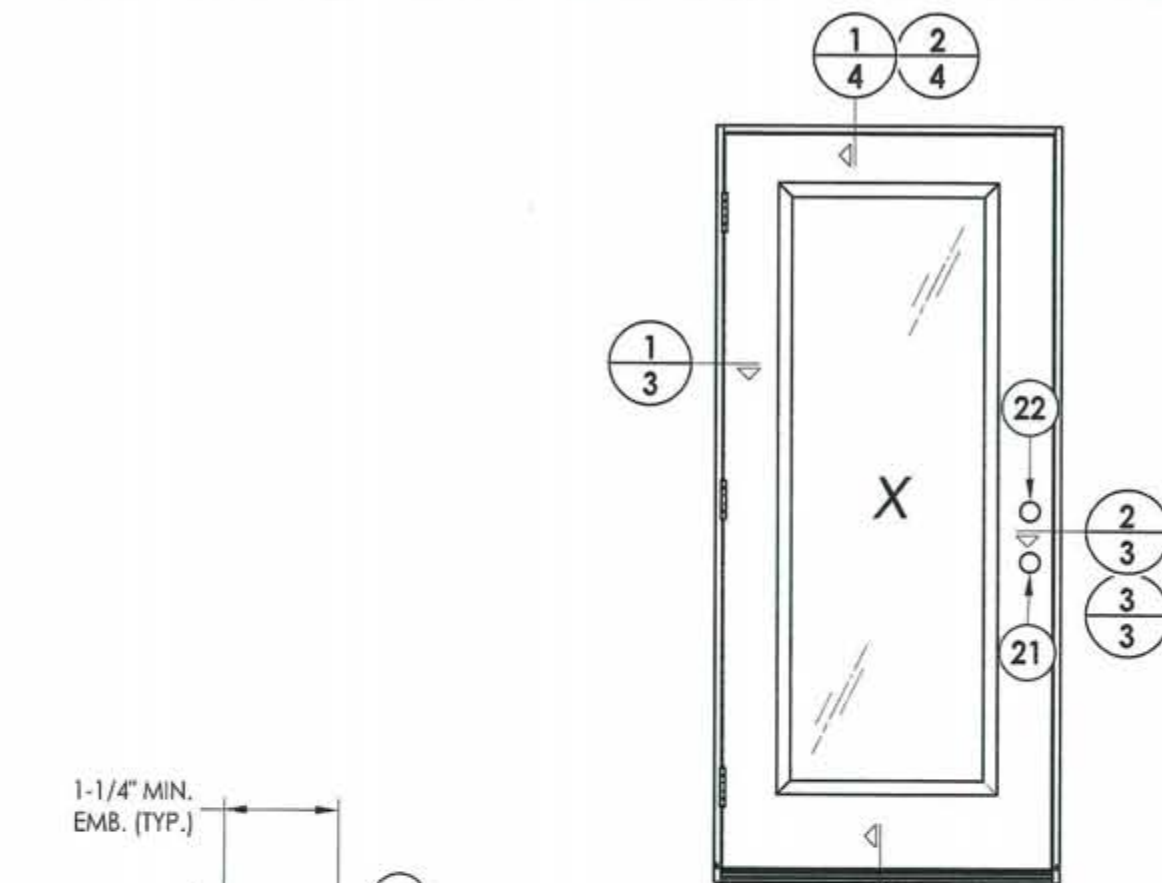

**1**  
**3** **HORIZONTAL CROSS SECTION**  
 Outswing shown  
 Inswing also approved

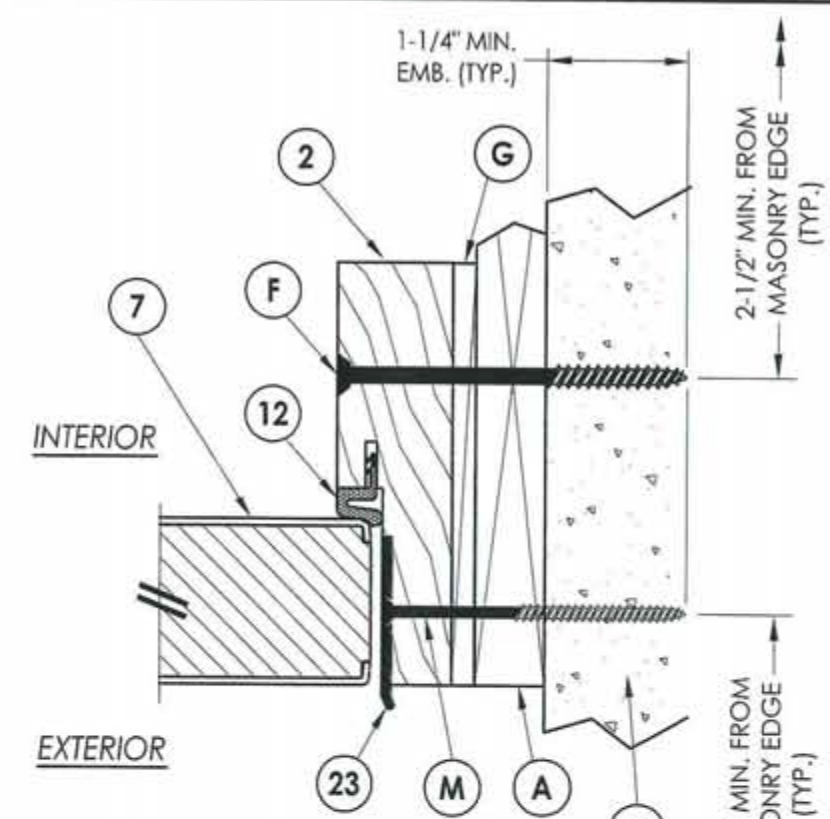

**3**  
**3** **HORIZONTAL CROSS SECTION**  
 Shown w/1X sub-buck substituting  
 concrete screws for wood screws per  
 Section 1714.5.4.2 of the FBC

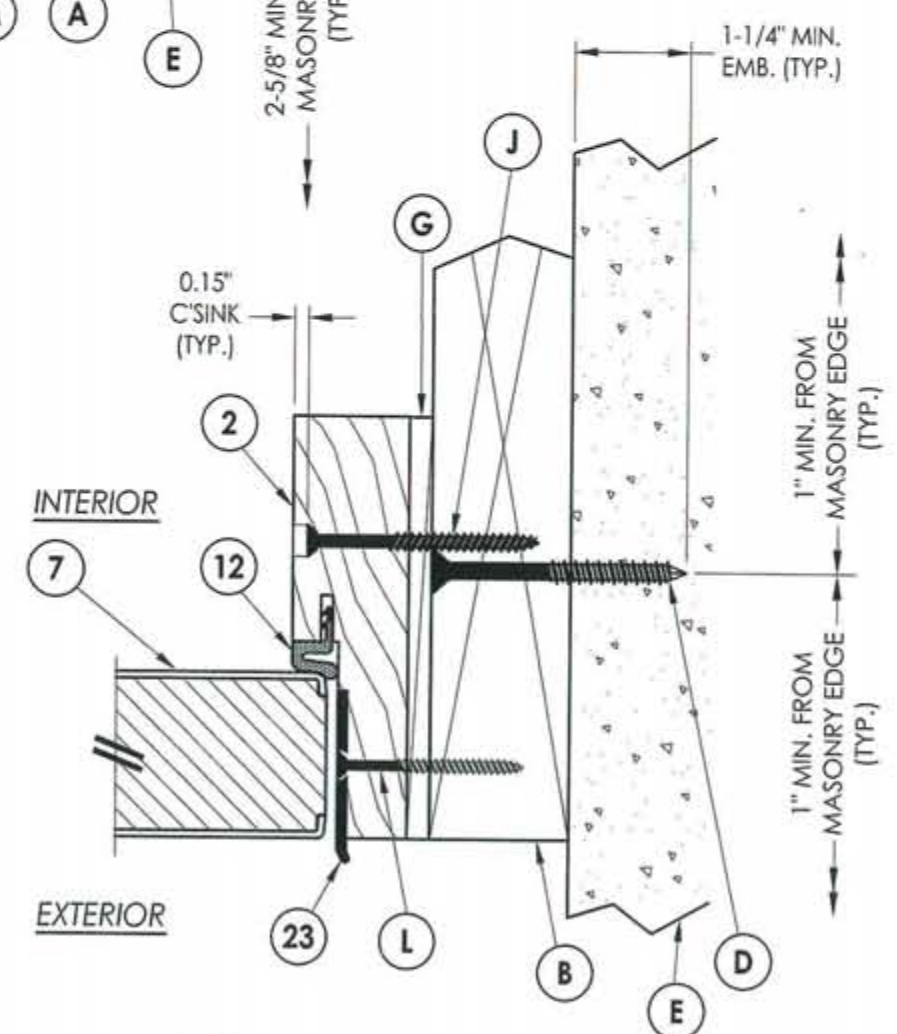

**2**  
**3** **HORIZONTAL CROSS SECTION**  
 Outswing shown  
 Inswing also approved

Documents Prepared By: <b>RW</b> BUILDING CONSULTANTS, INC. P.O. Box 230 Valrico FL 33595 Phone No.: 813.659.9197 Florida Board of Professional Engineers Certificate Of Authorization No. 9813 <i>Wendell W. Handy</i> 5-1-08 Wendell W. Handy, P.E. No. 54158	
PRODUCT: TRINITY GLASS INT'L PREMIUM LIPLITE FIBERGLASS	PART OR ASSEMBLY: HORIZONTAL CROSS SECTIONS
NO. DATE REVISIONS	BY
DATE: 5/09/08 SCALE: N.T.S. DWG. BY: YV CHK. BY: WWH DRAWING NO.: FL-11165.1	SHEET 3 OF 8

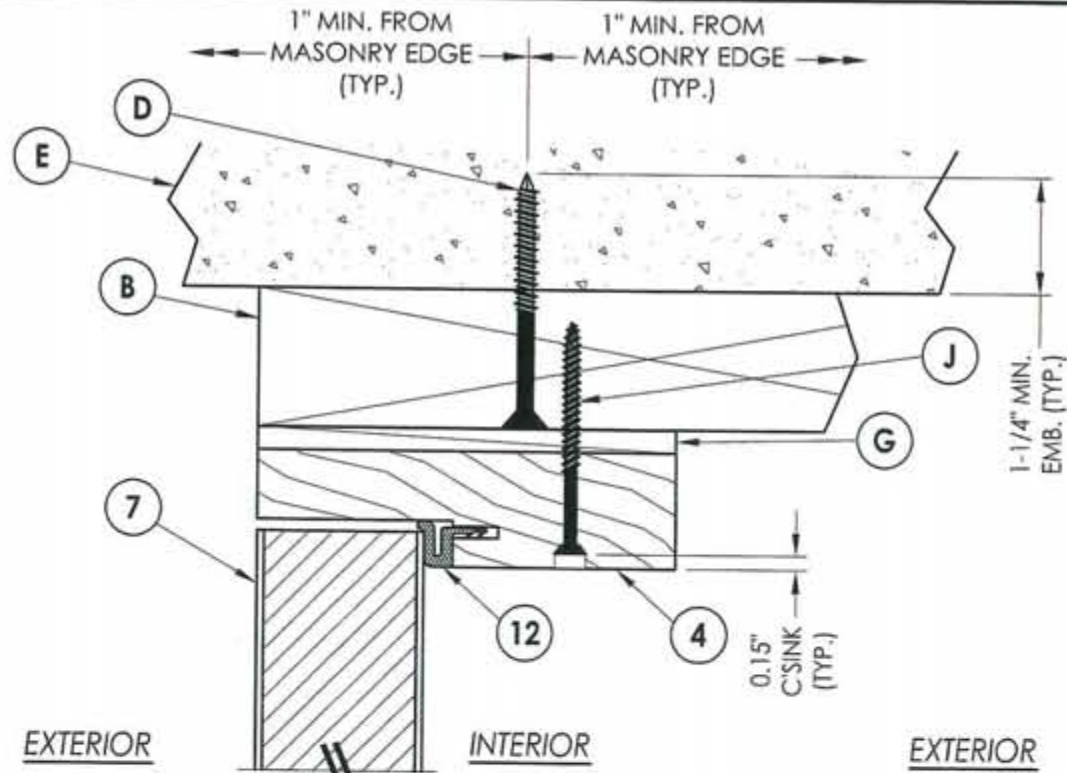

**1** VERTICAL CROSS SECTION  
**4** Outswing shown  
 Inswing also approved

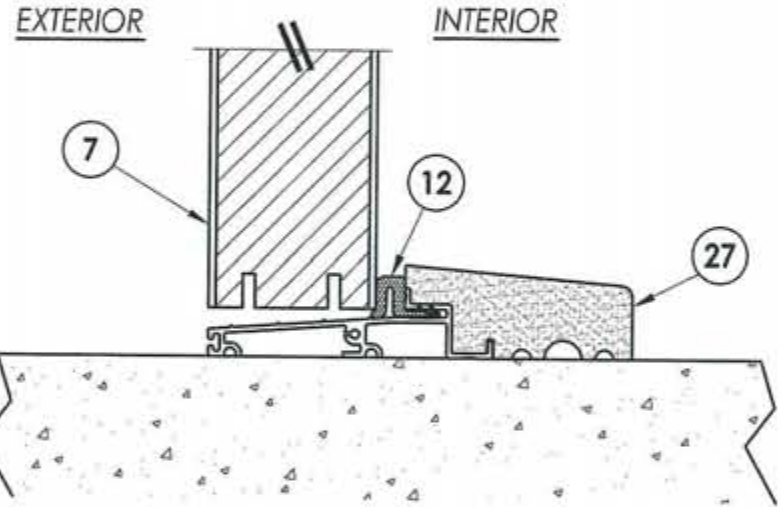

EXTERIOR INTERIOR

**4** VERTICAL CROSS SECTION  
**4** Outswing configuration  
 see general notes, sheet 1  
 for "HVHZ" water infiltration  
 requirements

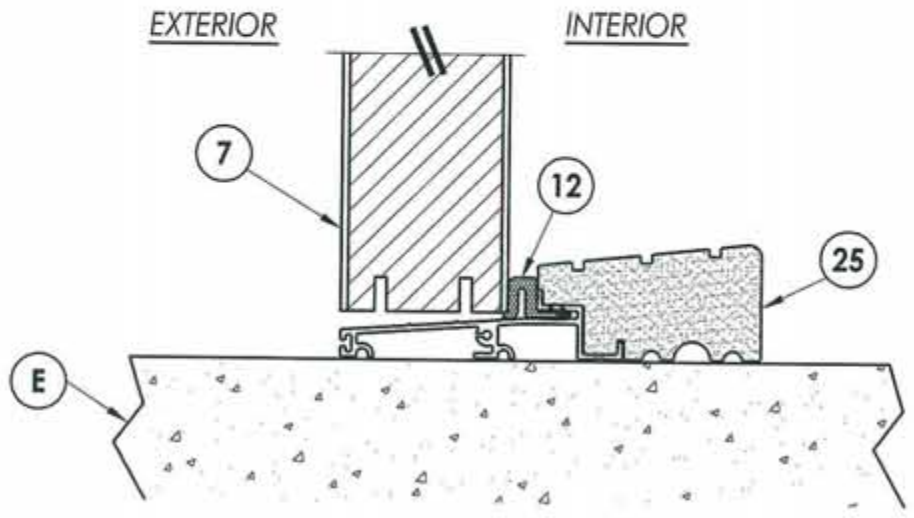

EXTERIOR INTERIOR

**3** VERTICAL CROSS SECTION  
**4** Outswing configuration  
 see general notes, sheet 1  
 for "HVHZ" water infiltration  
 requirements

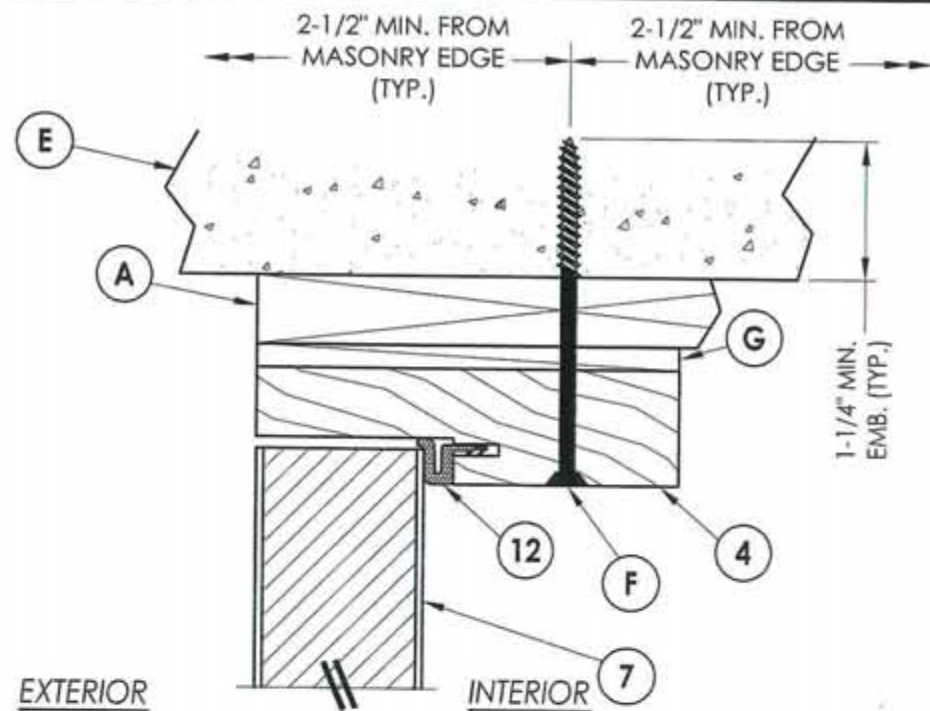

EXTERIOR INTERIOR

**2** VERTICAL CROSS SECTION  
**4** Shown w/1X sub-buck substituting  
 concrete screws for wood screws per  
 Section 1714.5.4.2 of the FBC

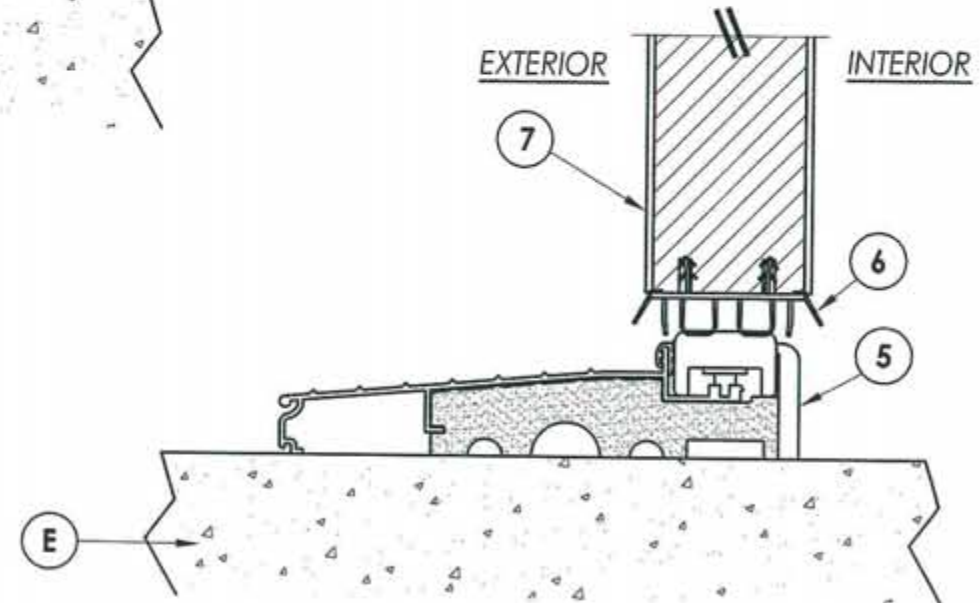

EXTERIOR INTERIOR

**5** VERTICAL CROSS SECTION  
**4** Inswing configuration  
 see general notes, sheet 1  
 for "HVHZ" water infiltration  
 requirements

Documents Prepared By:  
**RW** BUILDING CONSULTANTS, INC.  
 P.O. Box 230 Vairico FL 33595  
 Phone No.: 813.659.9197  
 Florida Board of Professional Engineers  
 Certificate Of Authorization No. 9813  
*Wendell W. Haney, P.E.* 5-1-08  
 Wendell W. Haney, P.E. No. 54158

PRODUCT: TRINITY GLASS INT'L PREMIUM LIPLITE FIBERGLASS  
 PART OR ASSEMBLY: VERTICAL CROSS SECTIONS

NO.	DATE	BY	REVISIONS

DATE: 5/09/08  
 SCALE: N.T.S.  
 DWG. BY: YV  
 CHK. BY: WWH  
 DRAWING NO.: FL-11165.1  
 SHEET 4 OF 8

© 2008 R.W. BUILDING CONSULTANTS INC.



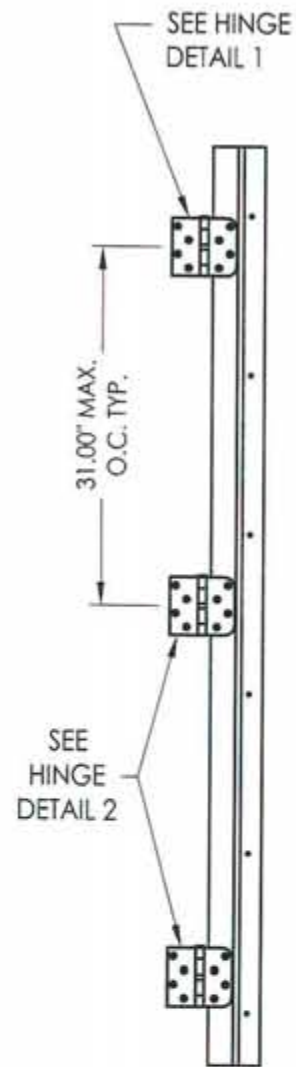

**HINGE JAMB**

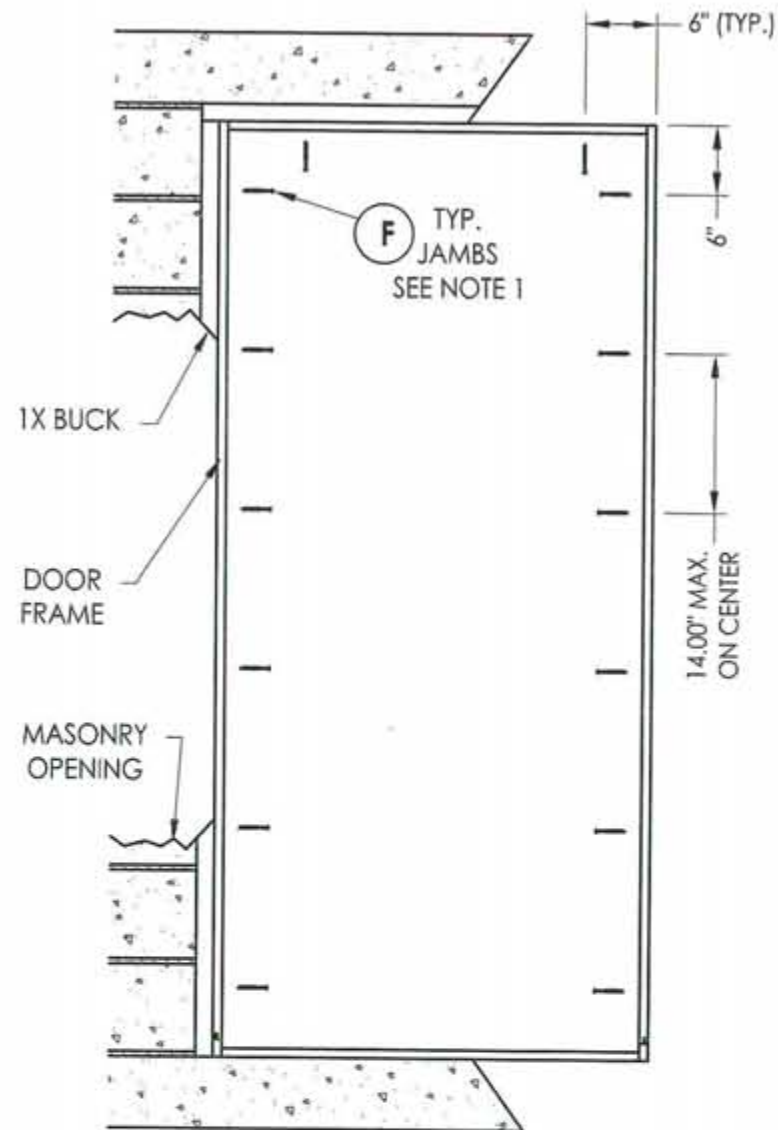

**FRAME ANCHORING**  
Masonry 1X buck construction

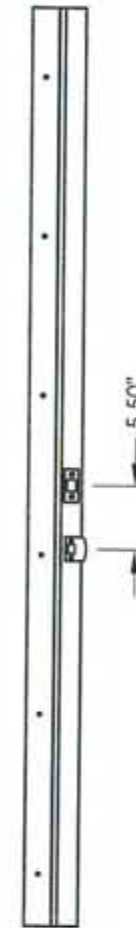

**STRIKE JAMB**

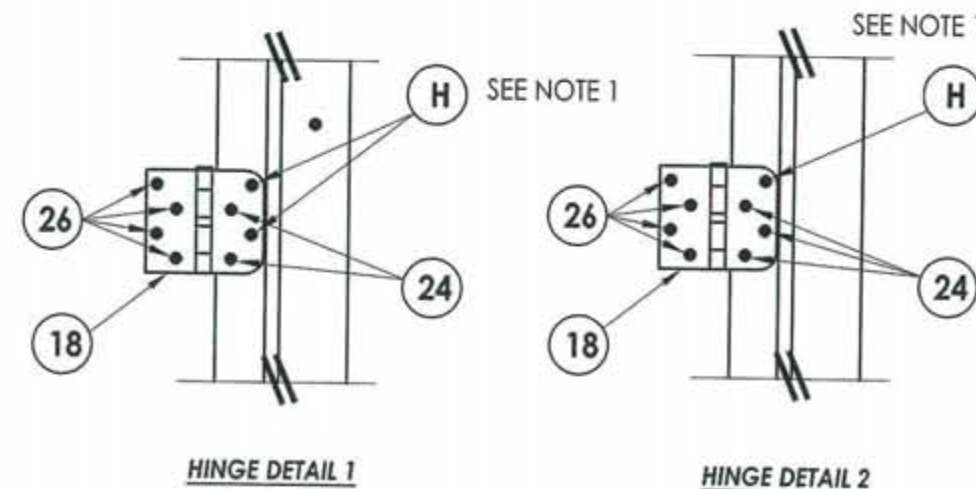
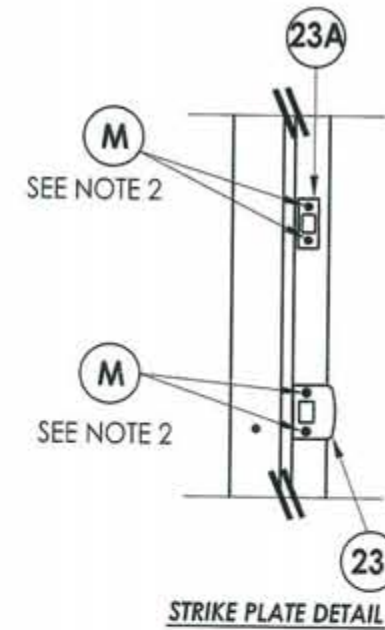

**NOTES:**

- 1/4" ITW concrete screws anchoring frame and/or sill require a minimum 2-1/2" clearance to masonry edges, a 1-1/4" minimum embedment and a minimum 3" clearance to adjacent concrete screws. Substitution of equal concrete screws from a different supplier may have different edge distance and center distance requirements. Concrete screw locations at the corners may be adjusted to maintain the minimum edge distance to mortar joints. If concrete screw locations noted as "MAX. ON CENTER" must be adjusted to maintain the minimum edge distance to mortar joints, additional concrete screws may be required to ensure the maximum on center dimension is not exceeded.
- 3/16" ITW concrete screws anchoring frame and/or sill require a minimum 2-5/8" clearance to masonry edges, a 1-1/4" minimum embedment and a minimum 2-1/4" clearance to adjacent concrete screws unless otherwise noted by concrete screw manufacturer.

Documents Prepared By:  
**RW** BUILDING CONSULTANTS, INC.  
 P.O. Box 230 Valrico FL 33595  
 Phone No.: 813.659.9197  
 Florida Board of Professional Engineers  
 Certificate of Authorization No. 9813  
*Wendell W. Harley* B-1-08  
 Wendell W. Harley, P.E. No. 54158

PRODUCT: TRINITY GLASS INT'L PREMIUM LIPLITE FIBERGLASS  
 PART OR ASSEMBLY: FRAME ANCHORING 1X BUCK MASONRY CONSTRUCTION

NO.	DATE	BY	REVISIONS

DATE: 5/09/08  
 SCALE: N.T.S.  
 DWG. BY: YV  
 CHK. BY: WWH  
 DRAWING NO.: FL-11165.1  
 SHEET 6 OF 8



